

SLE20/KE-W1 Unpacking Instructions

This document describes the unpacking process for the SLE20 and/or KE-W1. See the steps below.

NOTE: HEAVY OBJECT – UNIT WEIGHS 300 POUNDS

- Set palletized laser enclosure on a flat, stable surface. To remove the crate, simply follow the instructions included with the image on the bottom left.
- Remove shrink wrap and clip all straps wrapped around the unit.
- With a crane or forklift, **very carefully** lift the unit and place it in a designated area.
 - **NOTE:** There are two (2) ½-13 threaded holes beneath plastic caps that may be used with eyebolts for lifting.

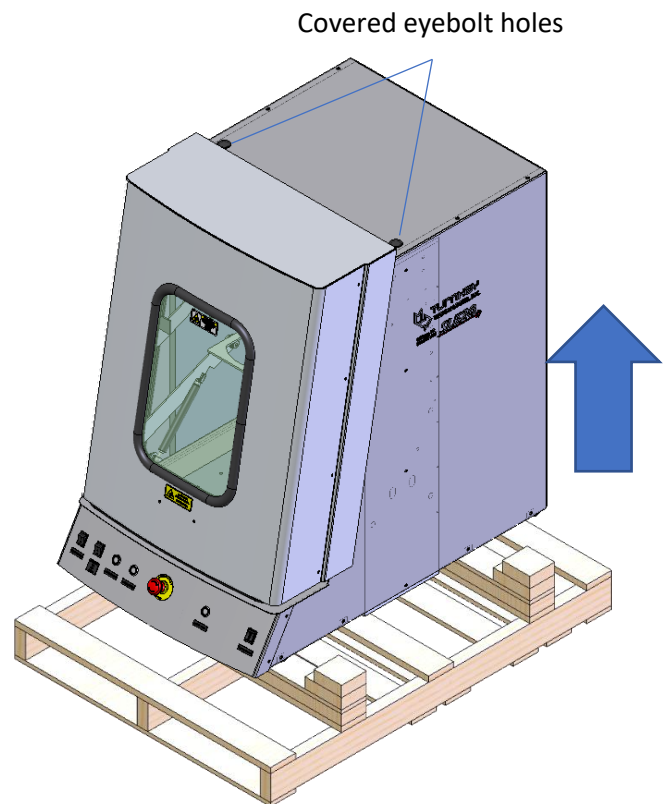
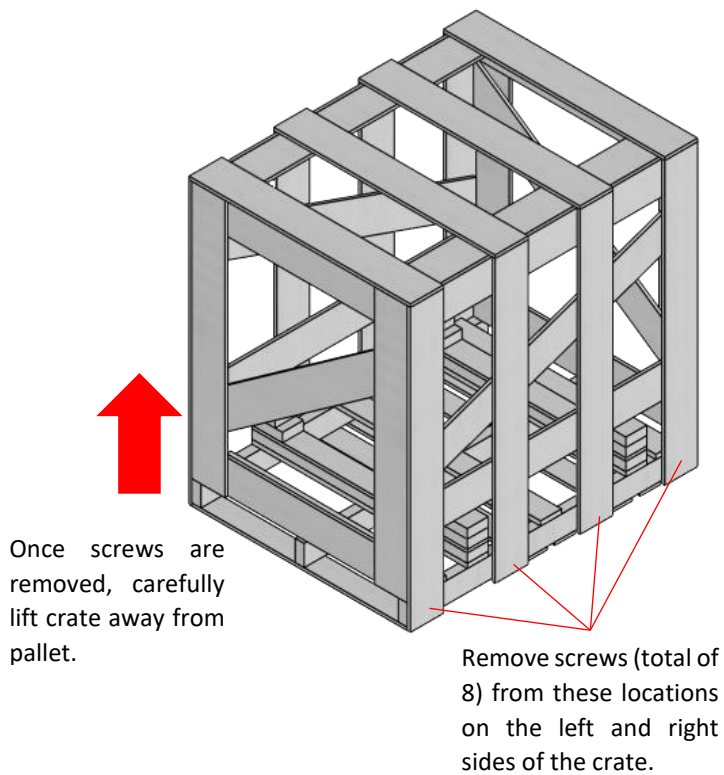

SLE20/KE-W1 Repacking Instructions

This document describes the repacking process for the SLE20 and/or KE-W1. See the steps below.

NOTE: HEAVY OBJECT – UNIT WEIGHS 300 POUNDS

- Set the laser enclosure pallet on a flat, stable surface.
- With a crane or forklift, **very carefully** lift the unit and place it on the pallet, so that the center of the unit is aligned with the centermost plank, as illustrated in the image below on the left.
 - NOTE: There are two (2) ½-13 threaded holes beneath plastic caps that may be used with eyebolts for lifting.
- Once on the pallet, add corner protectors to the top of the unit. Then, route straps under the pallet and overtop the enclosure. The result should resemble the image on the right.
- Shrink wrap the unit to add an extra protective layer and secure the door closed on any manual door variants.
- Finally, place the crate frame over the unit and attach it to pallet using wood screws.

